

ATKINSON, NEBRASKA

AL-9257 (FAA)

VORTAC ONL 113.9 Chan 86	APP CRS 279°	Rwy Idg TDZE Apt Elev	3900 2123 2128
----------------------------------------------	------------------------	-----------------------------	-------------------------------------------

VOR/DME RWY 29
ATKINSON/STUART-ATKINSON MUNI (8V2)

Use O'Neill altimeter setting. NA	MISSED APPROACH: Climb to 3700 then right turn via ONL R-279 to AYFOY 11 DME and hold.
--------------------------------------	----------------------------------------------------------------------------------------

MINNEAPOLIS CENTER 128.0 385.5	CTAF 122.9
------------------------------------------	----------------------

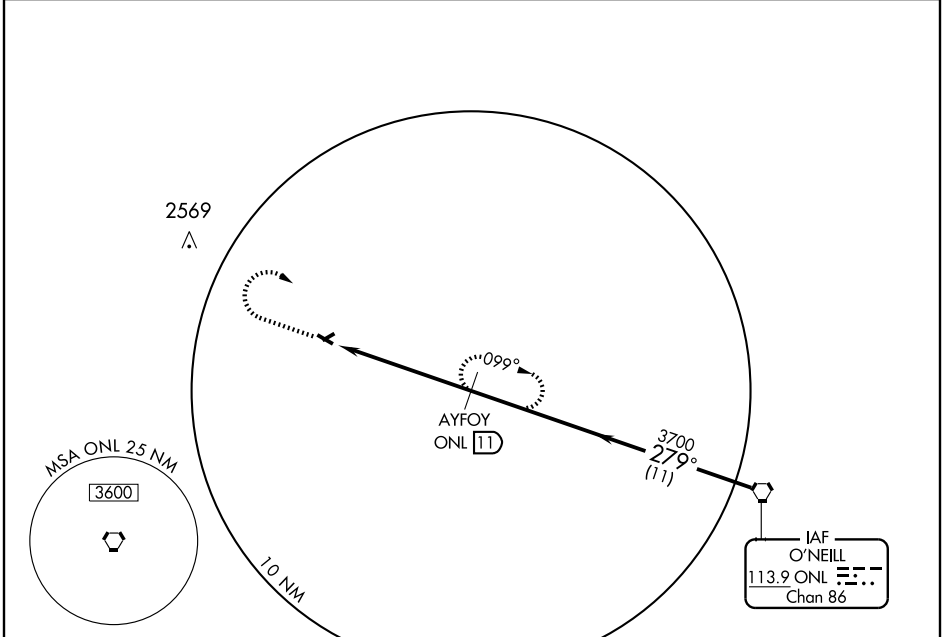

NC-2, 22 OCT 2009 to 19 NOV 2009

NC-2, 22 OCT 2009 to 19 NOV 2009

ELEV 2128	Rwy 29 ldg 3900'
-----------	------------------

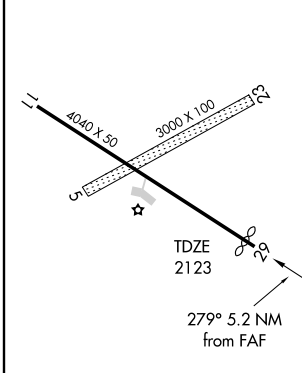

LIRL Rwy 11-29					
Knots	60	90	120	150	180
Min:Sec					

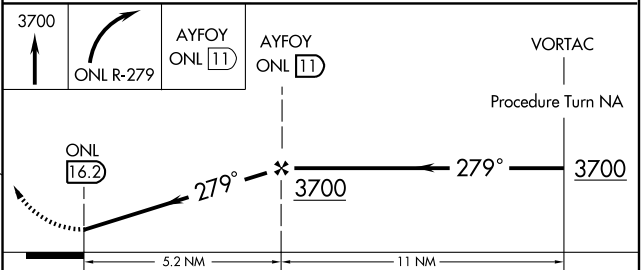

CATEGORY	A	B	C	D
S-29	2640-1	517 (600-1)	2640-1½ 517 (600-1½)	NA
CIRCLING	2640-1	512 (600-1)	2640-1½ 512 (600-1½)	NA

ATKINSON, NEBRASKA
Orig 05020

42°34'N-99°02'W

ATKINSON/STUART-ATKINSON MUNI (8V2)
VOR/DME RWY 29