

# LAKES FIVE DEPARTURE

ATIS 119.35  
KANSAS CITY DEP CON  
118.9 294.7

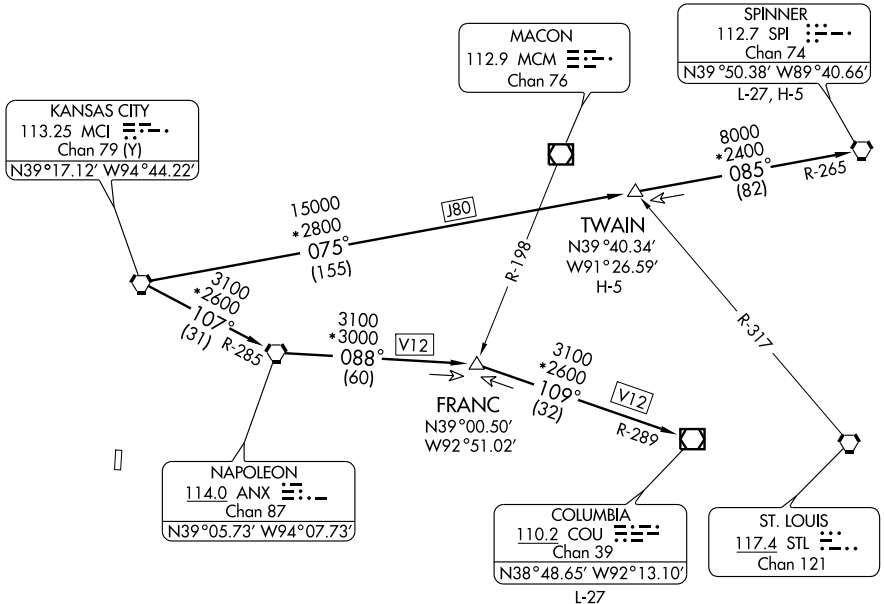

**TAKEOFF MINIMUMS:**  
Rwy 18, 36: Standard.

**NOTE:** Radar Required.  
**NOTE:** DME Required for TWAIN and SPINNER Transitions.

**Takeoff Obstacles:**

Rwy 18, multiple trees 622 feet from DER, 192 feet right of centerline, up to 73' AGL/1084' MSL.  
Rwy 36, antenna 335 feet from DER, 263 feet left of centerline, 20' AGL/1110' MSL. Tree 1008 feet from DER, 612 feet right of centerline, 57' AGL/1130' MSL. Tree 1544 feet from DER, 810 feet left of centerline, 71' AGL/1144' MSL.

NOTE: Chart not to scale.



## DEPARTURE ROUTE DESCRIPTION

Expect vectors to appropriate route. Expect filed altitude 10 minutes after departure.

**COLUMBIA TRANSITION (LAKES5.COU):** From over MCI VORTAC via MCI R-107 and ANX R-285 to ANX VORTAC, then via ANX R-088 to FRANC INT, then via COU R-289 to COU VOR/DME.

**SPINNER TRANSITION (LAKES5.SPI):** From over MCI VORTAC via MCI R-075 and SPI R-265 to TWAIN INT, then via SPI R-265 to SPI VORTAC.

**TWAIN TRANSITION (LAKES5.TWAIN):** From over MCI VORTAC via MCI R-075 and SPI R-265 to TWAIN INT.

NC-2, 22 OCT 2009 to 19 NOV 2009

NC-2, 22 OCT 2009 to 19 NOV 2009