

VOR/DME-B
INDIANOLA MUNI (IDL)

VOR/DME GLH 110.2 Chan 39	APP CRS 094°	Rwy Idg TDZE Apt Elev 126	N/A N/A 126
---	------------------------	---	--

▼ Use Greenville altimeter setting; if not received, use Greenwood altimeter setting and increase all MDA's 100 feet.
▲ NA

MISSED APPROACH: Climb to 1200 then climbing left turn to 3000 via R-094 to GLH VOR/DME and hold.

MEMPHIS CENTER
135.875 269.35

UNICOM
122.8 (CTAF)

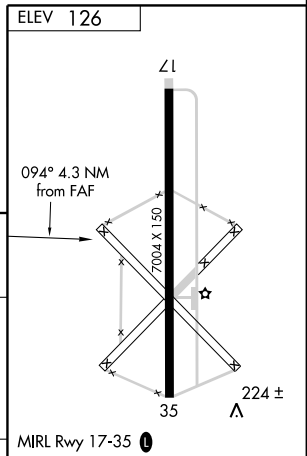
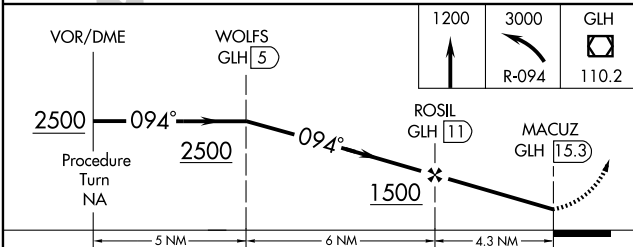
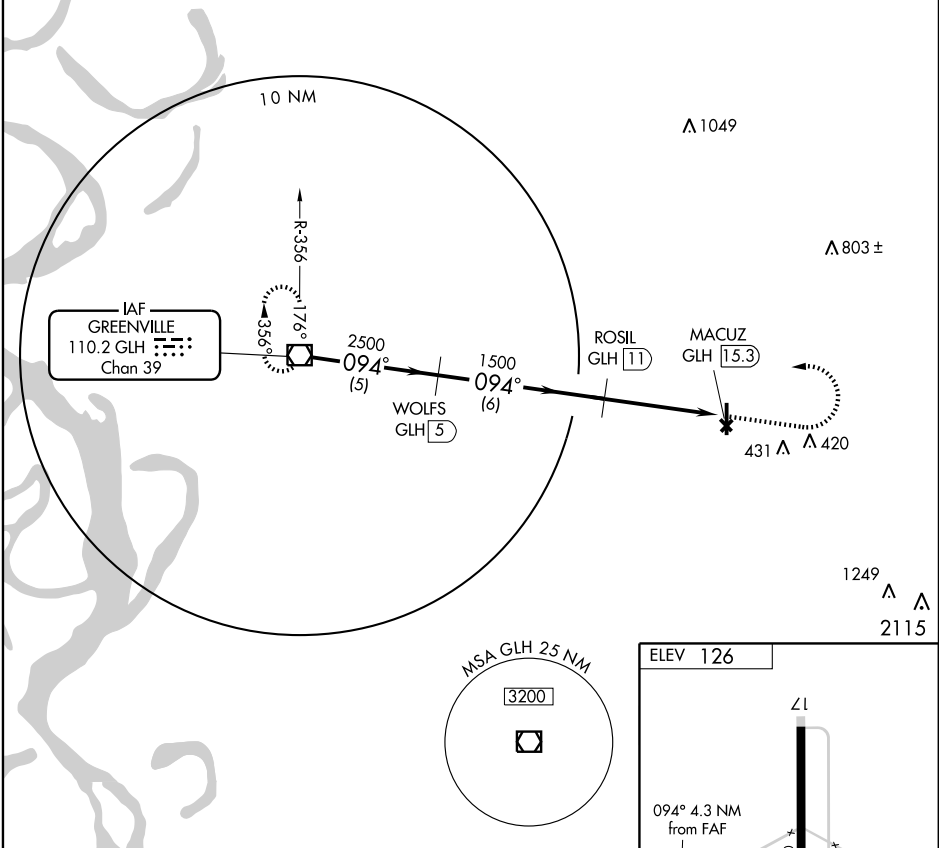

CATEGORY	A	B	C	D	Knots	60	90	120	150	180
CIRCLING	580-1	454 (500-1)	600-1½ 474 (500-1½)	780-2 654 (700-2)	Min:Sec					

SC-4, 22 OCT 2009 to 19 NOV 2009

SC-4, 22 OCT 2009 to 19 NOV 2009