

INDIANOLA, MISSISSIPPI

AL-5685 (FAA)

RNAV (GPS) RWY 17

INDIANOLA MUNI (IDL)

APP CRS 177°	Rwy Idg 7004
	TDZE 126
	Apt Elev 126

NA DME/DME RNP-0.3 NA. Use Greenville altimeter setting; if not received, use Greenwood altimeter setting and increase all MDAs 100 feet.

MISSED APPROACH: Climb to 2500 direct WUPUK and hold.

MEMPHIS CENTER 135.875 269.35	UNICOM 122.8 (CTAF) 0
---	---------------------------------

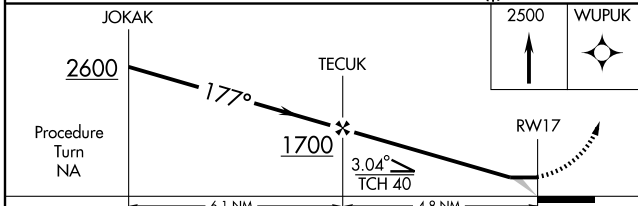
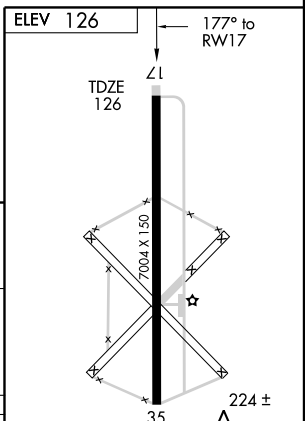
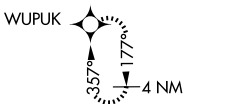
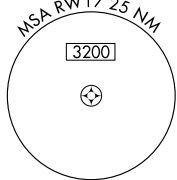
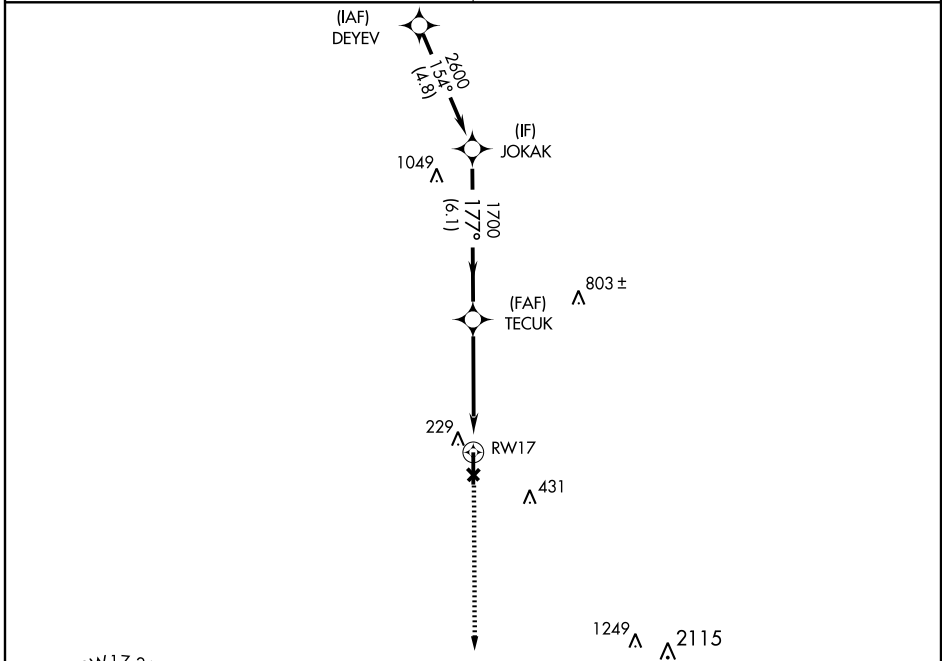

CATEGORY	A	B	C	D
LNVA MDA	520-1 394 (400-1)		520-1½ 394 (400-1½)	
CIRCLING	580-1	454 (500-1)	600-1½ 474 (500-1½)	780-2 654 (700-2)

MIRL Rwy 17-35 0

INDIANOLA, MISSISSIPPI
Orig 08269

33°29'N-90°40'W

INDIANOLA MUNI (IDL)

RNAV (GPS) RWY 17

SC-4, 22 OCT 2009 to 19 NOV 2009

SC-4, 22 OCT 2009 to 19 NOV 2009