

WAAS Ch 45908 W30A	APP CRS 300°	Rwy Idg TDZE Apt Elev	5000 1266 1274
--	------------------------	-----------------------------	---

RNAV (GPS) RWY 30

DENISON MUNI (DNS)

NA DME/DME RNP- 0.3 NA. Visibility reduction by helicopters NA. When local altimeter setting not received, use Carroll altimeter setting and increase all DA 72 feet and all MDA 80 feet. Increase LPV visibility ¼ mile all Cats, LNAV/VNAV visibility ½ mile all Cats, LNAV Cat C ¼ mile, and circling Cat C ¼ mile. BARO-VNAV NA when using Carroll altimeter setting. For uncompensated BARO-VNAV systems, LNAV/VNAV NA below -17°C (2°F) or above 54°C (130°F).

MISSED APPROACH: Climb to 3300 direct GECNU and hold.

AWOS-3 119.95	MINNEAPOLIS CENTER 119.6 290.4	UNICOM 122.8 (CTAF) 0
-------------------------	--	---------------------------------

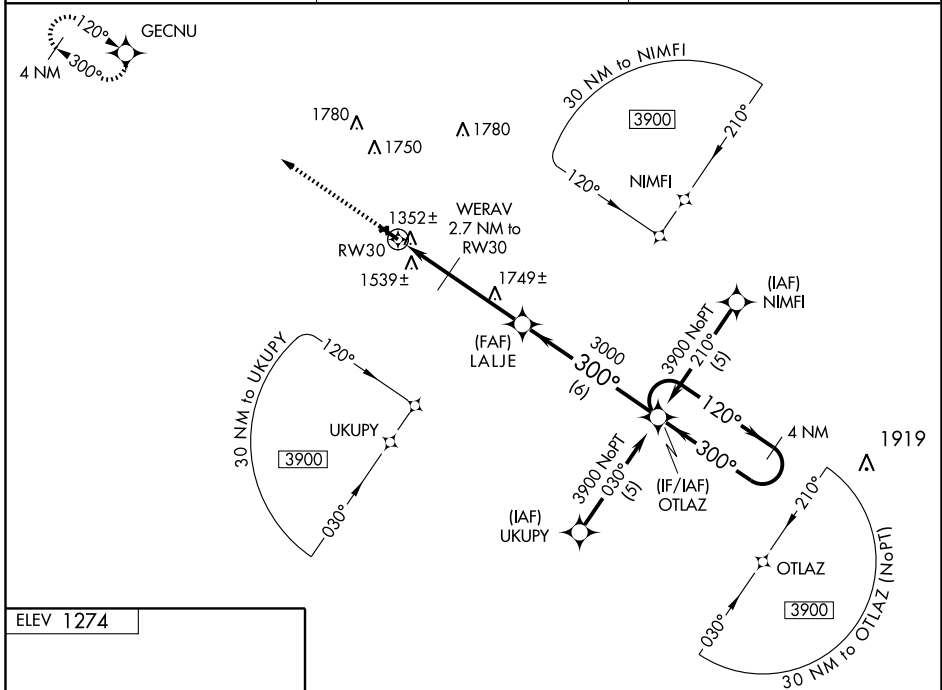

NC-3, 22 OCT 2009 to 19 NOV 2009

NC-3, 22 OCT 2009 to 19 NOV 2009

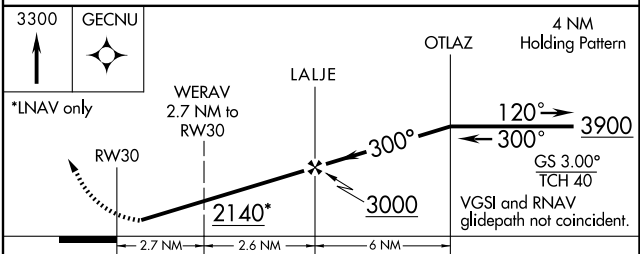
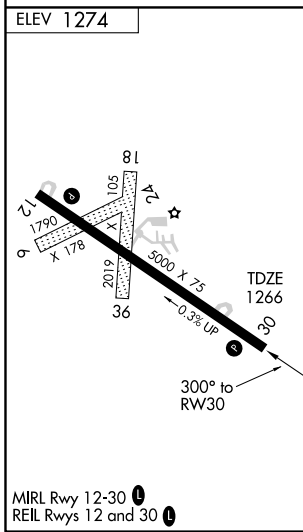

CATEGORY	A	B	C	D
LPV DA		1551-1 285 (300-1)		NA
LNAV/VNAV DA		1853-2 587 (600-2)		NA
LNAV MDA	1800-1 534 (600-1)		1800-1 ½ 534 (600-1 ½)	NA
CIRCLING	1840-1 566 (600-1)	1880-1 606 (700-1)	1880-1 ¾ 606 (700-1 ¾)	NA