

# RNAV (GPS) Y RWY 36

SEBRING RGNL (SEF)

APP CRS	Rwy Idg	<b>5234</b>
<b>005°</b>	TDZE	<b>62</b>
	Apt Elev	<b>62</b>

**▼** DME/DME RNP-0.3 NA. Visibility reduction by helicopters NA.  
**▲ NA** When local altimeter setting not received, use Vero Beach Muni altimeter setting and increase all MDA 140 feet, increase LNAV Cat. C and D visibility ½ mile, increase Circling Cat. C and D visibility ¼ mile.

MISSED APPROACH: Climbing left turn to 2000 direct EMBRU and hold.

AWOS-3 <b>119.475</b>	MIAMI CENTER <b>127.2 349.0</b>	UNICOM <b>122.7 (CTAF)</b>
--------------------------	------------------------------------	-------------------------------

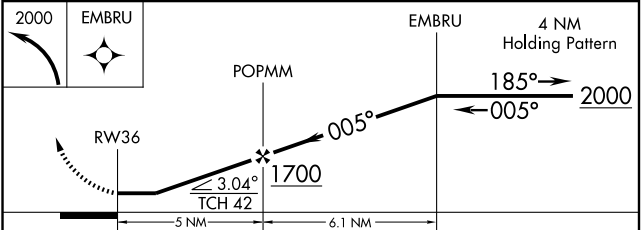
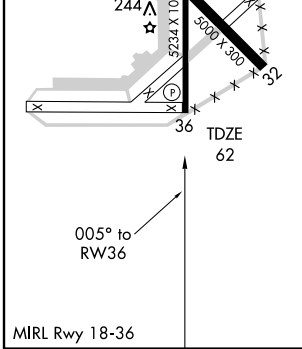
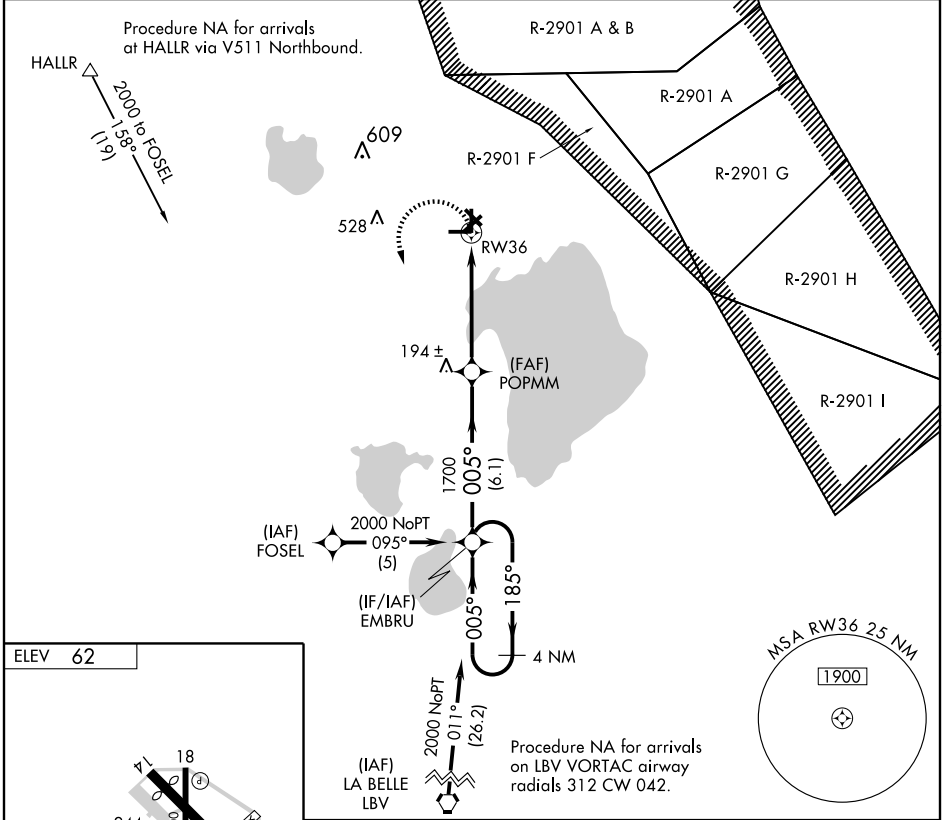

CATEGORY	A	B	C	D
LNAV MDA	540-1	478 (500-1)	540-1¼ 478 (500-1¼)	540-1½ 478 (500-1½)
CIRCLING	600-1	538 (600-1)	600-1½ 538 (600-1½)	620-2 558 (600-2)

SE-3, 22 OCT 2009 to 19 NOV 2009

SE-3, 22 OCT 2009 to 19 NOV 2009