

TRUAX TWO DEPARTURE

ASOS
 119.275
 CLNC DEL
 135.35 (When tower closed)
 GND CON
 118.625
 SCHOLES TOWER ★
 120.575 (CTAF)
 HOUSTON DEP CON
 134.45 284.0

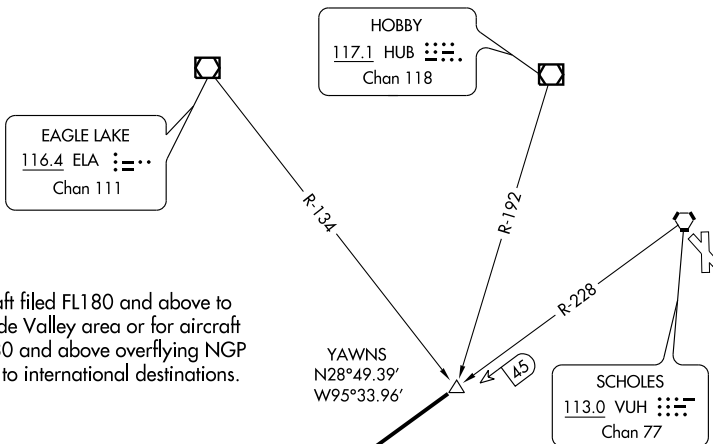

Note: For aircraft filed FL180 and above to Rio Grande Valley area or for aircraft filed FL180 and above overflying NGP VORTAC to international destinations.

TAKE-OFF MINIMUMS:
 Rwy 13, 31, 35 standard.
 Rwy 17, 200-1 or standard with a minimum climb of 502 feet per NM to 300.

TAKE-OFF OBSTACLES:

- Rwy 13, Bush, 381' from DER, 533' left of centerline, 15' AGL/20' MSL.
 Tree, 343' from DER, 468' right of centerline, 12' AGL/17' MSL.
 Fence, 201' from DER, 490' left of centerline, 6' AGL/11' MSL.
- Rwy 17, Multiple transmission towers beginning 636' from DER, 551' right of centerline, up to 55' AGL/60' MSL. Building 3057' from DER, 339' left of centerline, 123' AGL/130' MSL. Multiple poles beginning 2034' from DER, 87' right of centerline, up to 60' AGL/70' MSL.
 Tree, 460' feet from DER, 316' right of centerline, 22' AGL/29' MSL.
- Rwy 31, Multiple cranes beginning 4341' from DER, 1017' left of centerline, up to 131' AGL/131' MSL.
- Rwy 35, Tree, 730' from DER, 501' right of centerline, 27' AGL/32' MSL.

NOTE: Chart not to scale.

NOTE: Radar Required.

DEPARTURE ROUTE DESCRIPTION

When entering controlled airspace, fly assigned heading for vectors to YAWNS INT, maintain 4000', expect filed altitude 10 minutes after departure. Thence
 via VUH R-228 and NGP R-047 to NGP VORTAC.

SC-5, 22 OCT 2009 to 19 NOV 2009

SC-5, 22 OCT 2009 to 19 NOV 2009